

## LAB #18: Evolution and Classification

### **Objective:**

- In this investigation, students will use phylogenies to observe and understand relationships among different species.

### **Introduction:**

This lab is an adapted version of one created by Robert P. Gendron of Indiana University of Pennsylvania.

Humans classify almost everything, including each other. This habit can be quite useful. For example, when talking about a car someone might describe it as a 4-door sedan with a fuel injected V-8 engine. A knowledgeable listener who has not seen the car will still have a good idea of what it is like because of certain characteristics it shares with other familiar cars. Humans have been classifying plants and animals for a lot longer than they have been classifying cars, but the principle is much the same. In fact, one of the central problems in biology is the classification of organisms on the basis of shared characteristics. As an example, biologists classify all organisms with a backbone as "vertebrates." In this case the backbone is a characteristic that defines the group. If, in addition to a backbone, an organism has gills and fins it is a fish, a subcategory of the vertebrates. This fish can be further assigned to smaller and smaller categories down to the level of the species. The classification of organisms in this way aids the biologist by bringing order to what would otherwise be a bewildering diversity of species. (There are probably several million species - of which about one million have been named and classified.) The field devoted to the classification of organisms is called **taxonomy** [Gk. taxis, arrange, put in order + nomos, law].

The modern taxonomic system was devised by **Carolus Linnaeus** (1707-1778). It is a **hierarchical** system since organisms are grouped into ever more inclusive categories from species up to kingdom. **Figure 1** illustrates how four species are classified using this taxonomic system. (Note that it is standard practice to underline or *italicize* the genus and species names.)

KINGDOM	Animalia		Plantae	
PHYLUM	Chordata		Arthropoda	Angiospermophyta
CLASS	Mammalia		Insecta	Monocotyledoneae
ORDER	Primate	Carnivora	Hymenoptera	Liliales
FAMILY	Hominidae	Canidae	Apidae	Liliaceae
GENUS	<i>Homo</i>	<i>Canis</i>	<i>Apis</i>	<i>Alium</i>
SPECIES	<i>sapiens</i> (human)	<i>lupus</i> (wolf)	<i>mellifera</i> (honeybee)	<i>sativum</i> (garlic)

Figure 1

In the 18th century most scientists believed that the Earth and all the organisms on it had been created suddenly in their present form as recently as 4004 BC. According to this view, Linnaeus' system of classification was simply a useful means of cataloging the diversity of life. Some scientists went further, suggesting that taxonomy provided insight into the Creator's mind ("Natural Theology").

This view of taxonomy changed dramatically when **Charles Darwin** published *On The Origin of Species* in 1859. In his book Darwin presented convincing evidence that life had evolved through the process of **natural selection**. The evidence gathered by Darwin, and thousands of other biologist since then, indicates that all organisms are descended from a common ancestor. In the almost unimaginable span of time since the first organisms arose (about 3.5 billion years) life has gradually diversified into the myriad forms we see today.

As a consequence of Darwin's work it is now recognized that taxonomic classifications are actually **reflections of evolutionary history**. For example, Linnaeus put humans and wolves in the class Mammalia within the phylum Chordata because they share certain characteristics (e.g. backbone, hair, homeothermy, etc.). We now know that this similarity is not a coincidence; both species inherited these traits from the same **common ancestor**. In general, the greater the resemblance between two species, the more recently they diverged from a common ancestor. Thus when we say that the human and wolf are more closely related to each other than either is to the honeybee we mean that they share a common ancestor that is not shared with the honeybee.

Another way of showing the evolutionary relationship between organisms is in the form of a **phylogenetic tree** as shown in **Figure 2** (Gk. phylon, stock, tribe + genus, birth, origin):

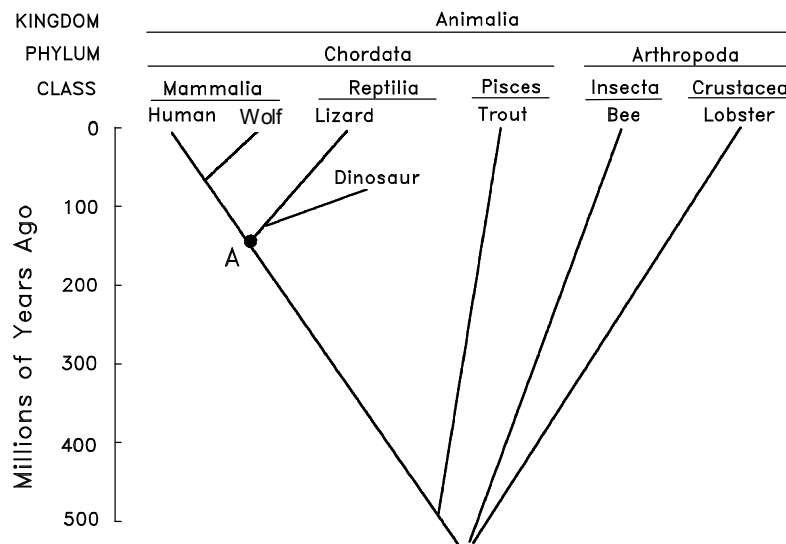

Figure 2

The vertical axis in this figure represents time. The point at which two lines separate indicates when a particular lineage split. For example, we see that mammals diverged from reptiles about 150 million years ago. The **most recent common ancestor** shared by mammals and reptiles is indicated by the point labeled A. The horizontal axis represents, in a general way, the amount of divergence that has occurred between different groups; the greater the distance, the more different their appearance. Note that because they share a fairly recent ancestor, species within the same taxonomic group (e.g. the class Mammalia) tend to be closer to each other at the top of the tree than they are to members of other groups.

Several types of evidence can elucidate the evolutionary relationship between organisms, whether in the form of a taxonomic classification (**Figure 1**) or a phylogenetic tree (**Figure 2**).

One approach, as already discussed, is to compare living species. The greater the differences between them, the longer ago they presumably diverged. There are, however, pitfalls with this approach. For example, some species resemble each other because they independently evolved similar structures in response to similar environments or ways of life, not because they share a recent common ancestor. This is called **convergent evolution** because distantly related species seem to converge in appearance (become more similar). Examples of convergent evolution include the wings of bats, birds and insects, or the streamlined shape of whales and fish. At first glance it might appear that whales are a type of fish. Upon further examination it becomes apparent that this resemblance is superficial, resulting from the fact that whales and fish have adapted to the same environment. The presence of hair, the ability to lactate and homeothermy clearly demonstrate that whales are mammals. Thus, the taxonomist must take into account a whole suite of characteristics, not just a single one.

The fossil record can also be helpful for constructing phylogenetic trees. For example, bears were once thought to be a distinct group within the order Carnivora. Recently discovered fossils, however, show that they actually diverged from the Canidae (wolves, etc.) fairly recently. The use of fossils is not without its problems, however. The most notable of these is that the fossil record is incomplete. This is more of a problem for some organisms than others. For example, organisms with shells or bony skeletons are more likely to be preserved than those without hard body parts.

### **The Classification and Evolution of Artificial Organisms**

In this lab you will develop a taxonomic classification and phylogenetic tree for a group of imaginary organisms called **Caminalcules** after the taxonomist Joseph Camin who devised them. At the back of this packet are pictures of the 14 "living" and 58 "fossil" species that you will use. Take a look at the pictures and note the variety of appendages, shell shape, color pattern, etc. Each species is identified by a number rather than a name. For fossil Caminalcules there is also a number in parentheses indicating the geological age of each specimen in millions of years. Most of the fossil Caminalcules are extinct, but you will notice that a few are still living (e.g. species #24 is found among the living forms but there is also a 2 million year old fossil of #24 in our collection).

The purpose of this lab is to illustrate the principles of classification and some of the processes of evolution (e.g. convergent evolution). We do these exercises with artificial organisms so that you will approach the task with no preconceived notion as to how they should be classified. This means that you will have to deal with problems such as convergent evolution just as a taxonomist would. With real organisms you would probably already have a pretty good idea of how they should be classified and thus miss some of the benefit of the exercise.

### Exercise 1: The Taxonomic Classification of Living Caminalcules

Carefully examine the fourteen living species and note the many similarities and differences between them. Using pencil in the space below, create a hierarchical classification of these species, using the format in **Figure 3**. Instead of using letters (A, B, ...), as in this example, use the number of each Caminalcule species. Keep in mind that **Figure 3** is just a hypothetical example. Your classification may look quite different than this one.

PHYLUM CAMINALCULA												
CLASS 1						CLASS 2						
ORDER 1						ORDER 2			ORDER 3			
FAMILY 1				FAMILY 2		FAMILY 3			FAMILY 3			
GENUS 1		GENUS 2		GENUS 3		GENUS 4		GENUS 5			GENUS 6	
<b>A</b>	<b>G</b>	<b>H</b>	<b>D</b>	<b>B</b>		<b>J</b>	<b>L</b>	<b>E</b>	<b>K</b>	<b>C</b>	<b>F</b>	<b>I</b>

Figure 3

The first step in this exercise is to decide which species belong in the same genus. Species within the same genus share characteristics not found in any other genera (plural of genus). The Caminalcules numbered 19 and 20 are a good example; they are clearly more similar to each other than either is to any of the other living species so we would put them together in their own genus. Use the same procedure to combine the genera into families. Again, the different genera within a family should be more similar to each other than they are to genera in other families. Families can then be combined into orders, orders into classes and so on. Depending on how you organize the species, you may only get up to the level of order or class. You do not necessarily have to get up to the level of Kingdom or Phylum.

### Classification of the 14 Living Caminalcules

## Exercise 2: The Comparative Approach to Phylogenetic Analysis

Using pencil in the space below, construct a phylogenetic tree based only on your examination of the 14 living species. This tree should reflect your taxonomic classification. For example, let us say you have put species A and G into the same genus because you think they evolved from a common ancestor ( $x$ ). Their part of the tree would look like the diagram on the right.

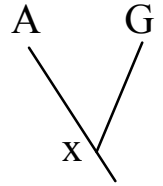

When there are three or more species in a genus you must decide which two of the species share a common ancestor not shared by the other(s). This diagram indicates that species E and K are more closely related to each other than either is to C. We hypothesize that E and K have a common ancestor ( $y$ ) that is not shared by C. Similarly, two genera that more closely resemble each other than they do other genera presumably share a common ancestor. Thus, even in the absence of a fossil record it is possible to develop a phylogenetic tree. We can even infer what a common ancestor like  $y$  might have looked like.

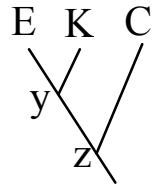

## Phylogenetic Tree of the 14 Living Caminalcules

### Exercise 3: The Phylogeny of Caminalcules

Using a large sheet of paper, construct a phylogenetic tree for the Caminalcules. Use a meter stick to draw 20 equally spaced horizontal line on the paper. Each line will be used to indicate an interval of one million years. Label each line so that the one at the bottom of the paper represents an age of 19 million years and the top line represents the present (0 years).

Cut out all the Caminalcules (including the living species). Put them in piles according to their age (the number in parentheses). Beginning with the oldest fossils, arrange the Caminalcules according to their evolutionary relationship. **Figure 4** shows how to get started.

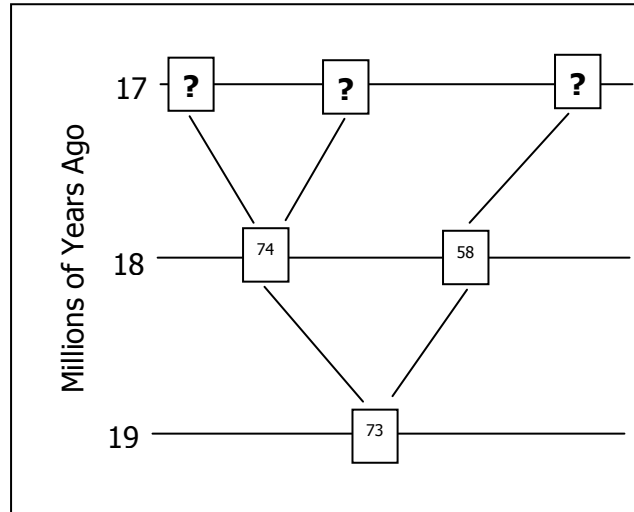
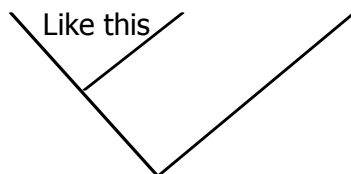

Figure 4

#### Hints, Suggestions and Warnings

- Draw lines faintly in pencil to indicate the path of evolution. Only after your instructor has checked your tree should you glue the figures in place and darken the lines.
- Branching should involve only two lines at a time:



like this

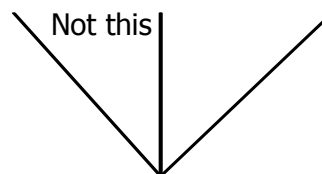

not like this

- Some living forms are also found in the fossil record.
- There are gaps in the fossil record for some lineages. Also, some species went extinct without leaving any descendants (remember the dinosaurs, Fig. 1).
- The Caminalcules were numbered at random; the numbers provide no clues to evolutionary relationships.
- There is only one correct phylogenetic tree in this exercise. This is because of the way that Joseph Camin derived his imaginary animals. He started with the most primitive form (#73) and gradually modified it using a process that mimics evolution in real organisms. After you complete your phylogeny compare it with Camin's original.

**POST-LAB QUESTIONS:**

1. You will notice that some **lineages** (e.g. the descendants of species 56) branched many times and are represented by many living species. Discuss the ecological conditions that you think might result in the rapid diversification of some lineages (A real world example would be the diversification of the mammals at the beginning of the Cenozoic, right after the dinosaurs went extinct.)

---

---

---

---

---

2. Some lineages (e.g. the descendants of species 58) changed very little over time. A good example of this would be "living fossils" like the horseshoe crab or cockroach. Again, discuss the ecological conditions that might result in this sort of long-term evolutionary stasis.

---

---

---

---

---

3. Some Caminalcules went extinct without leaving descendants. In the real world, what factors might increase or decrease the probability of a species going extinct?

---

---

---

---

---

4. Find two additional examples of **convergent evolution** among the Caminalcules. This means finding cases where two or more species have a similar characteristic that evolved independently in each **lineage**. The wings of bats, birds and bees is an example of convergence since the three groups did not inherit the characteristic from their **common ancestor**. Write your answers in complete sentences (e.g. "Species *x* and *y* both have \_\_\_\_ but their most recent common ancestor, *z*, did not").

---



---



---

5. Describe two examples of **vestigial structures** that you can find among the Caminalcules. These are structures that have been reduced to the point that they are virtually useless. Ear muscles and the tail bones are examples of vestigial structures in our own species.

---



---



---



---

6. Based on the following phylogenetic tree showing the evolutionary relationships of five species (A–E) relative to five traits (1–5), fill in the table using '+' to indicate the presence of a derived trait and 'O' to indicate the presence of an ancestral trait.

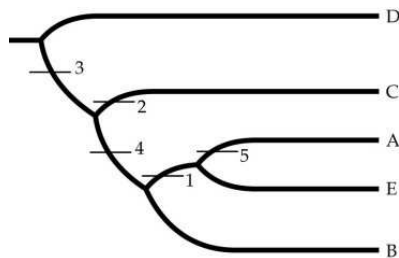

SPECIES	TRAIT				
	1	2	3	4	5
A					
B					
C					
D					
E					

7. In the phylogenetic tree shown in Question 1, which species is considered the outgroup? Explain your answer.

---



---



---

8. Based on the following table showing the ancestral and derived traits of five species (A–E), construct a phylogenetic tree below (like the one given in Question 6) that represents the evolutionary relationships of this group using conventions presented in the textbook. In this table, the ancestral state of each trait is indicated by '0', and the derived state is indicated by '+'.

SPECIES	TRAIT				
	1	2	3	4	5
A	+	+	+	0	0
B	0	0	0	0	0
C	+	+	0	+	0
D	0	+	0	0	0
E	+	+	0	+	+

9. Discuss the implications the following statement has for systematics: "DNA is the genetic material for all prokaryotes and eukaryotes."

---

---

---

---

---

10. In the diagram below, circle the root of the tree. What does this indicate?



11. **Diagram** - Which of the three phylogenetic trees of the *Drosophila* species below is different from the other two? What is the difference between that tree and the other two?

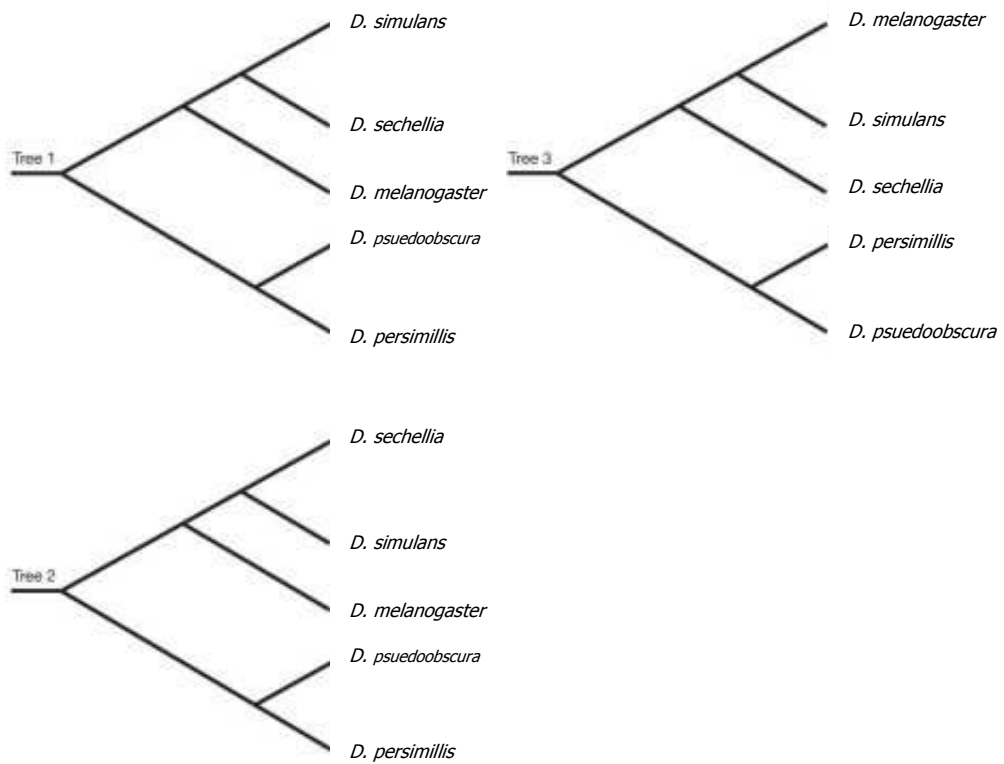

---



---



---

**LIVING CAMINALCULES**

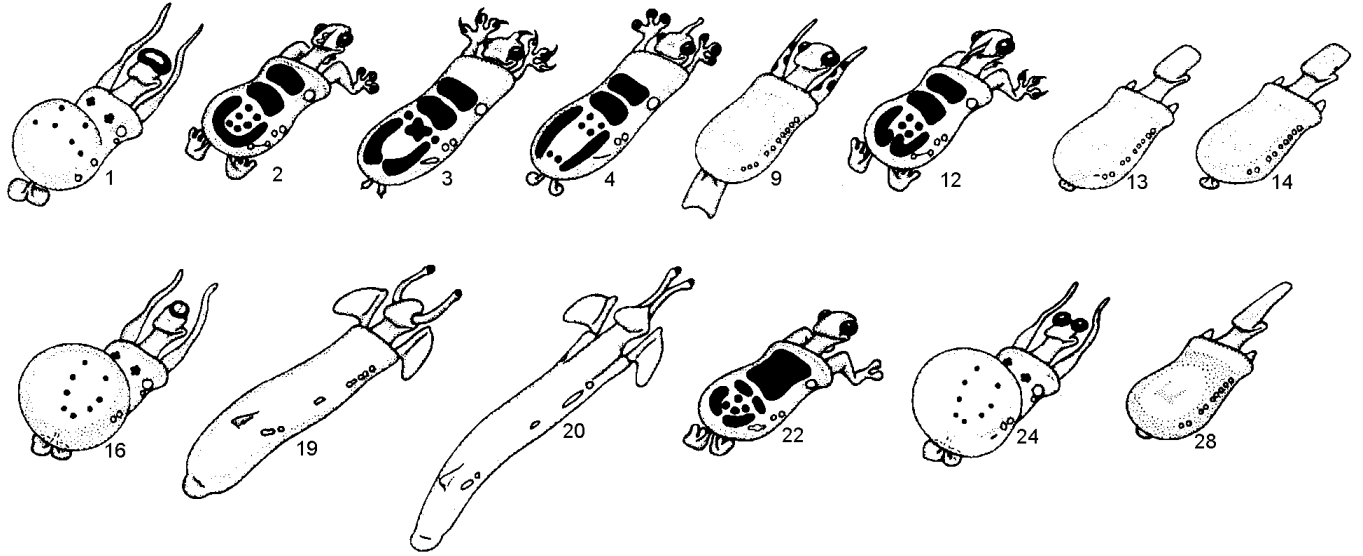

**FOSSIL CAMINALCULES**

(numbers in parentheses indicate age in millions of years)

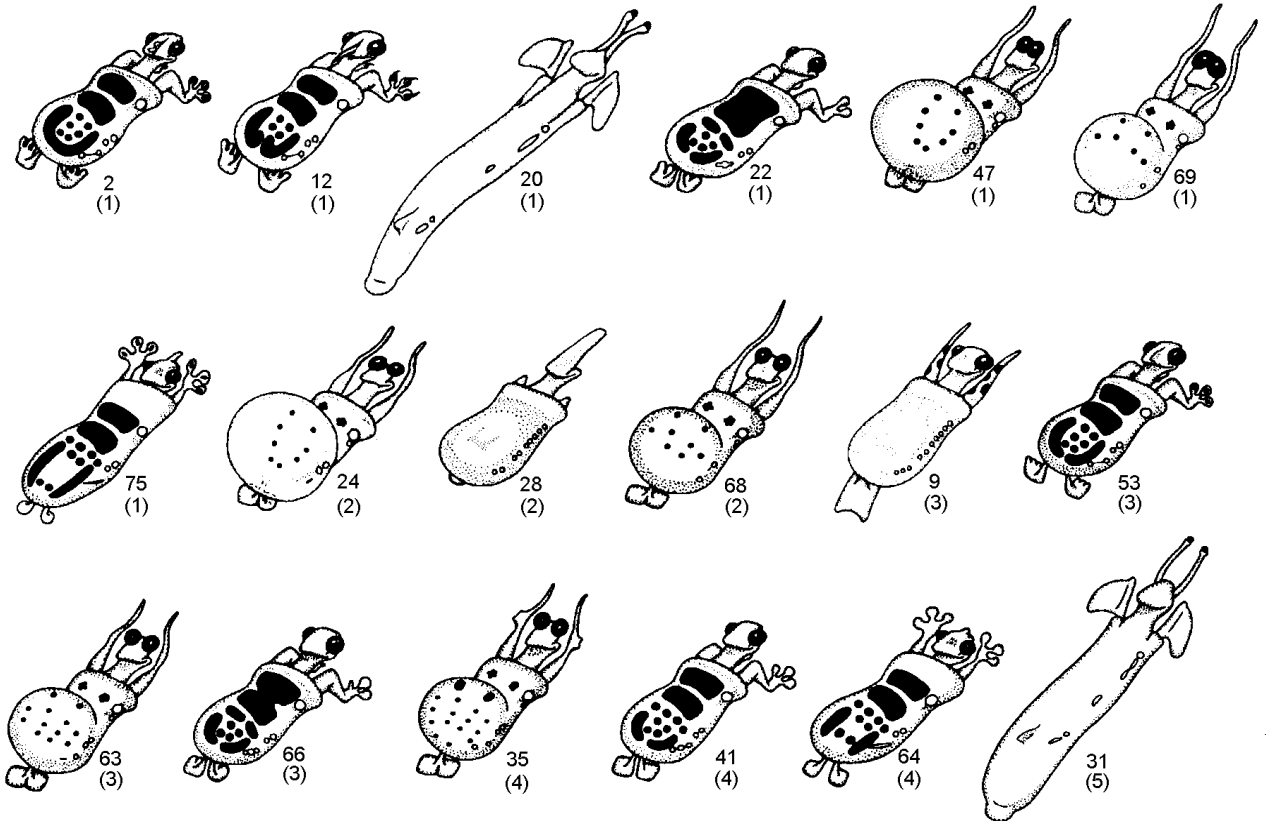

Name: \_\_\_\_\_

### **FOSSIL CAMINALCULES** (continued)

